



**We build trust**



**40**  
YEAR  
warranty





# NEXE GRUPA IS RESPONSIBLY BUILDING A NEW FUTURE



The tradition of making natural clay tiles began back in 1907, when AD POLET IGK factory in Novi Bečej was founded.

100 years later, we are proud that our tiles continue to cover roofs in the country, the region and throughout Europe.

For years, we have been listening very carefully to the needs of our customers, which have been guiding us in following technological trends in production, constantly expanding our product range, and maintaining a

high level of quality in tile manufacture. With the aim of retaining satisfied customers, suppliers and employees, we always strive for the highest standards in production, range and business. We have been a proud holder of ISO 9001-2015 certificate for years, which is awarded for the highest European product quality standards (CE).



As recognized leaders in business, our mission is to become recognized leaders in the field of socially responsible business.

We are responsibly building a new future and for this reason we are constantly investing in new technologies that reduce pollution emissions, we have improved our waste management system, thus setting high company goals for environmental protection.



NEXE tiles are made completely of natural materials, and thanks to their functionality and applicability, they can equally be used in continental and Mediterranean areas. Due to the engobing process, which contains a mix of natural clay, powder and metal pigments, tiles are made in different colors with smooth and shiny finish. Engobing slows down tile corrosion process and further prolongs the basic aesthetic appearance of the roof. Each tile has a 40-year quality and life warranty.



**BIBER**

**40**  
YEAR  
warranty





## BIBER roof tile

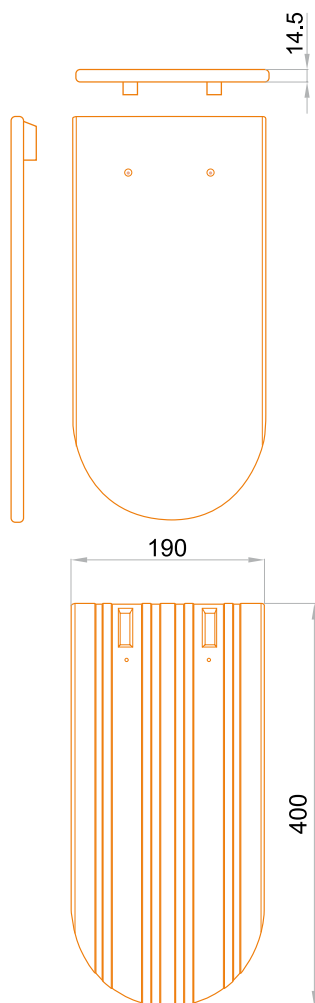

**BIBER** roof tile, as one of the oldest tile models, can be applied in various building design projects due to their simple appearance. They are used for renovation of old traditional buildings, which are a significant cultural heritage, but occupy no less important place in contemporary architecture.









Due to their simple, classic shape, they can be used as a highlighting decoration of a smaller roof area or as complete roof covering. This tile model is obtained by high-quality clay drawing technology rather than pressing.

By kiln firing at high temperatures, high-quality tile microstructure is achieved, which significantly contributes to excellent frost resistance and long service life.



Natural

Tested according to SRPS EN 1304

-  • Tile weight approx. **2kg**
-  • Individual size approx. **400x190mm**
-  • Recommended batten spacing (Double lap) **150 - 170mm**
-  • Recommended batten spacing (Single lap) **300 - 310mm**
-  • Minimum roof pitch **30°**
-  • Consumption per 1m<sup>2</sup> of roof **30,4 - 36 pcs**
-  • Packing of **560** pieces on a pallet (packing weight approx. 1.140kg)
-  • Packaging size **900x1000mm**

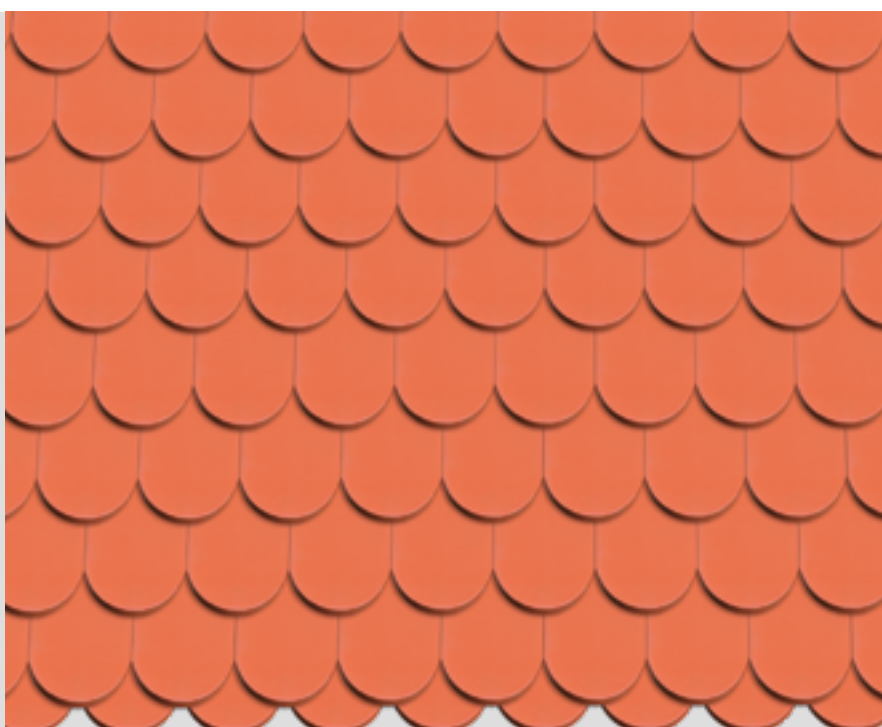

# GLINEX TREND

**40**  
YEAR  
warranty





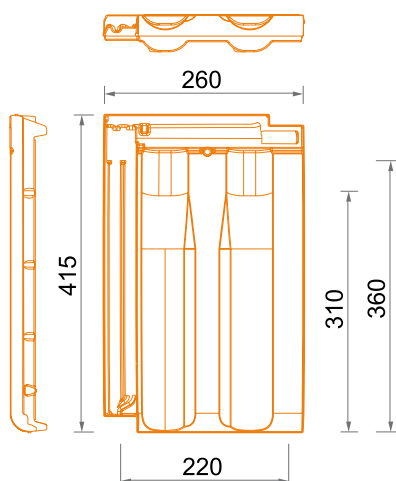









## Glinex Trend roof tile

**Glinex Trend** belongs to the pressed roof tiles category. Deep double seams enable excellent roof surface sealing. The most important advantage of using Glinex Trend tiles over other similar clay tiles is its constructive design that enables **sliding roof slating in a 31.5 cm to 35.5 cm range**. This method of installing Glinex Trend tiles eliminates errors that may occur during roof structure construction and the construction of the tile itself allows easy replacement of the old tile on the already existing roof plane. Glinex Trend is available in natural and engobed variants, in bordeaux, brown, black, copper and and Anthracite Grey.



Tested according to SRPS EN 1304

-  • Tile weight **2,9 - 3,2kg**
-  • Individual size approx. **415x260mm**
-  • Maximum covering length approx. **360mm**
-  • Covering width approx. **220mm**
-  • Recommended batten spacing approx. **31.5cm - 35.5cm**
-  **22°** • Minimum roof pitch **22°**
-  • Consumption per 1m<sup>2</sup> of roof **12.5 - 14.7 pcs**
-  • Packing of **320** pieces on a pallet (packing weight approx. 1.000kg)
-  • Packaging size **1133x850mm**

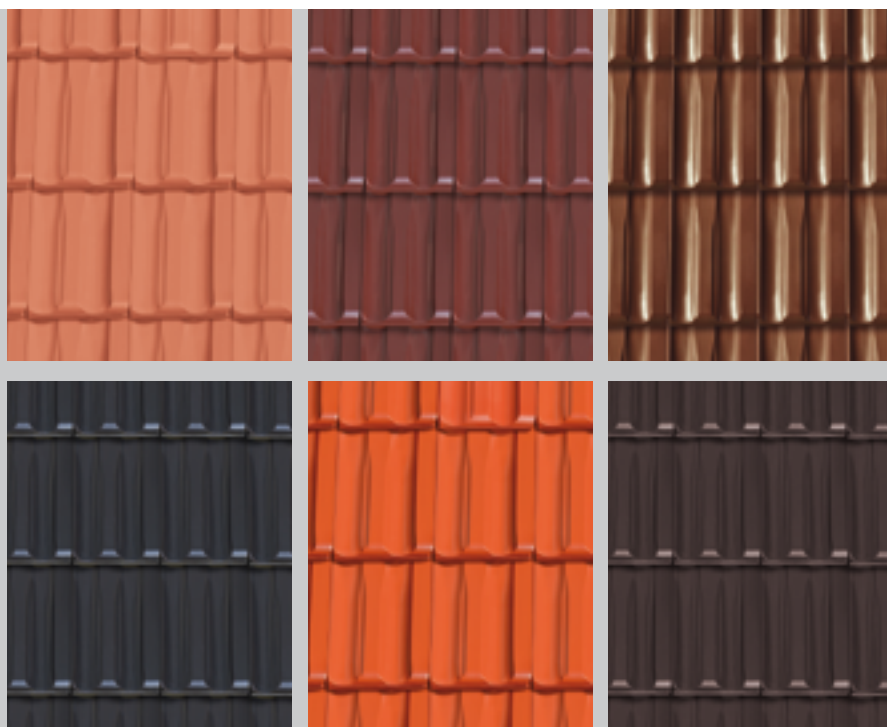

## SPECIAL ELEMENTS

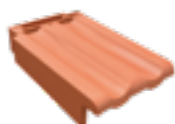

**End tile left**



**End tile right**

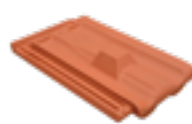

**Snowfance**



**Ventilation tile**

Special elements are available in natural, bordeaux, brown, black, copper and and Anthracite Grey.

# KLASIK PLUS

**40**  
YEAR  
warranty

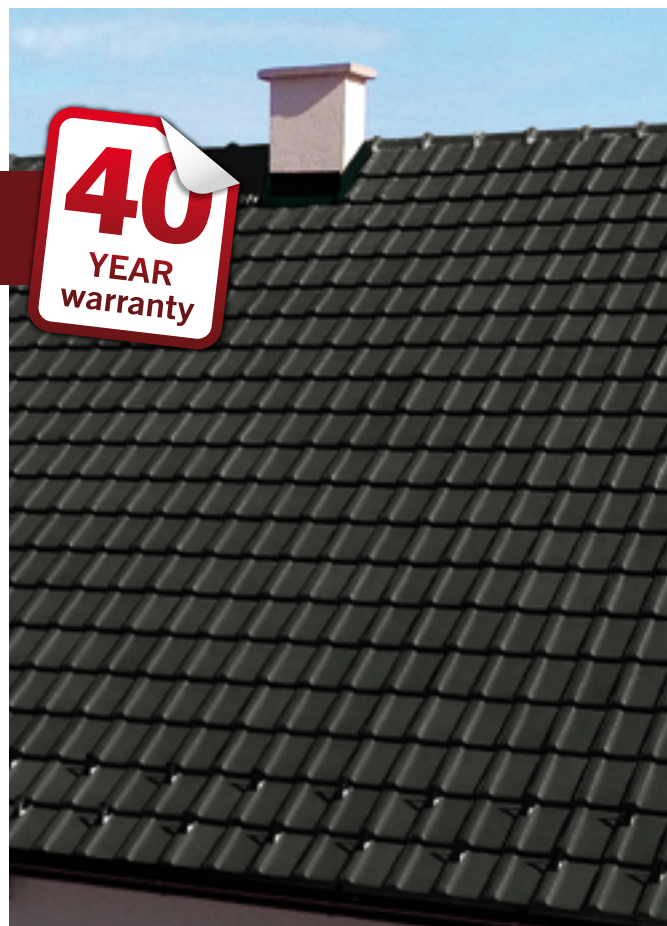



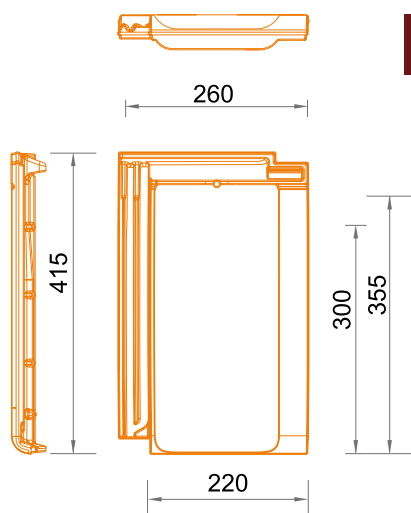









## Klasik Plus roof tile

**Klasik Plus** belongs to the pressed roof tiles category. Deep double seams enable excellent roof surface sealing. The most important advantage of using Klasik Plus tiles over other similar clay tiles is its constructive design that enables **sliding roof slating in a 30.0 cm to 35.0 cm range**. This method of installing KLASIK PLUS tiles eliminates errors that may occur during roof structure construction and the construction of the tile itself allows easy replacement of the old tile on the already existing roof plane. Klasik Plus is available in natural and engobed variants, in bordeaux, brown, black, copper and and Anthracite Grey.



Tested according to SRPS EN 1304

-  • Tile weight **2.9 - 3.1kg**
-  • Individual size approx. **415x260mm**
-  • Maximum covering length approx. **360mm**
-  • Covering width approx. **220mm**
-  • Recommended batten spacing approx. **30.0cm - 35.0cm**
-  **22°** • Minimum roof pitch **22°**
-  • Consumption per 1m<sup>2</sup> of roof **12.8 - 15.0 pcs**
-  • Packing of **320** pieces on a pallet (packing weight approx. 1.000kg)
-  • Packaging size **1133x850mm**

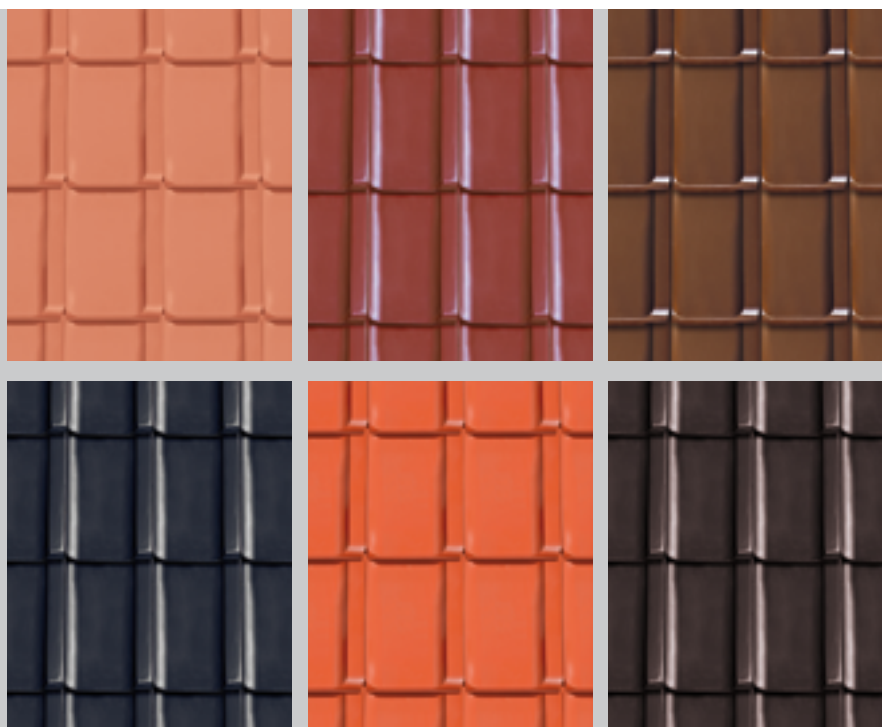

## SPECIAL ELEMENTS

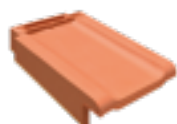

**End tile left**

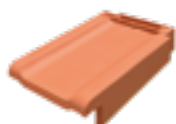

**End tile right**

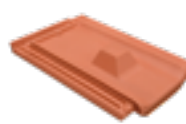

**Snowfance**



**Ventilation tile**

Special elements are available in natural, bordeaux, brown, black, copper and and Anthracite Grey.

# IDEAL PLUS

**40**  
YEAR  
warranty

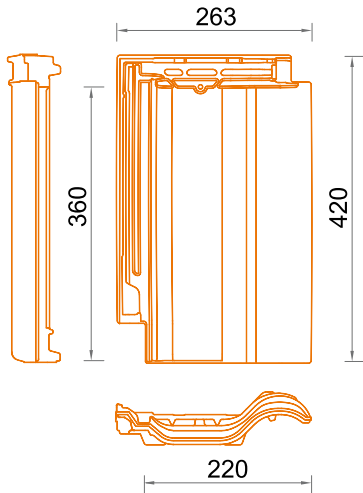

## Ideal Plus roof tile

**Ideal Plus** is a new roof tile model from the Nexe tile family. Double-seamed tile, semi-Mediterranean with sliding slating option. The most important advantage of using Ideal Plus roof tiles over other similar clay tiles is its constructive design that enables **sliding roof slating in a 34.0 cm to 35.5 cm range**. This method of installing Ideal plus tiles eliminates errors that may occur during roof structure construction and the construction of the tile itself allows easy replacement of the old tile on the already existing roof plane. Ideal Plus is available in beech wood color finish.

Tested according to SRPS EN 1304



• Tile weight **2,8 - 3,1kg**



• Individual size approx. **420x263mm**



• Maximum covering length approx. **360mm**



• Covering width approx. **220mm**



• Recommended batten spacing approx. **34.0cm - 35.5cm**



• Minimum roof pitch **22°**



• Consumption per 1m<sup>2</sup> of roof **12.5 - 14.0 pcs**



• Packing of **256 pieces** on a pallet (packing weight approx. 790kg)



• Packaging size **1133x850mm**



Natural



## SPECIAL ELEMENTS



End tile left



End tile right



Snowfance



Ventilation tile

Special elements are available in natural.



# IDEAL

**40**  
YEAR  
warranty

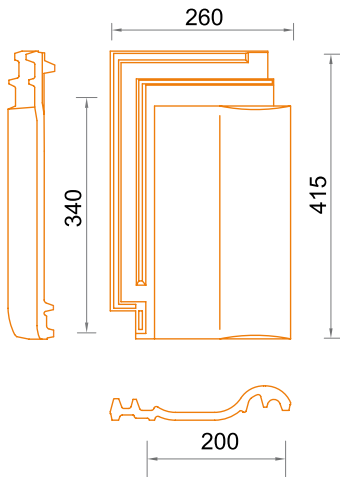

## Ideal roof tile

**Ideal** is a clay tile produced by modern manufacturing technology in "U" - cassettes, baked at a temperature of 1040 °C. It belongs to the family of semi-Mediterranean tiles. With its geometry and sealing characteristics, it is suitable for all weather conditions, especially in windy areas. Pressing with gypsum molds gives this tile a striking appearance and a pronounced relief, especially of grooving, which enables extremely easy fitting on the roof and roof tightness. **Ideal** is recognized for its excellent functionality, accurate dimensions and double seam. Available in natural color.

Tested according to SRPS EN 1304



• Tile weight **2,9 - 3,2kg**



• Individual size approx. **415x260mm**



• Maximum covering length approx. **350mm**



• Covering width approx. **200mm**



• Recommended batten spacing approx. **34cm**



• Minimum roof pitch **22°**



• Consumption per 1m<sup>2</sup> of roof **14.7 pcs**



• Packing of **320 pieces** on a pallet (packing weight approx. 1.000kg)



• Packaging size **1133x850mm**

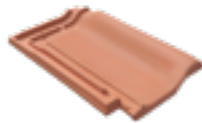

Natural



## SPECIAL ELEMENTS



End tile left



End tile right

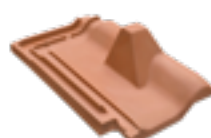

Snowfance

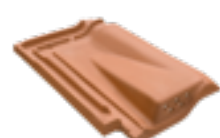

Ventilation tile

Special elements are available in natural.

# ROOF RIDGE TILE

With its geometry and shape, Glinex klasik ridge tile is compatible with every tile model from the NEXE product range. Thanks to its easy fitting with special elements, Glinex klasik is a simple solution for even the most demanding roofs. It is recognizable by its excellent functionality and quality workmanship, and is available in natural, bordeaux, brown, black, copper and Anthracite Grey.



• Consumption per 1m  
**2.65 pcs**



**Natural**



**Bordeaux**



**Brown**



**Black**



**Copper**



**Anthracite Grey**



# RIDGE TILE SPECIAL ELEMENTS

## Triple divider



Natural | Bordeaux | Brown | Black | Copper | Anthracite Grey

## Beginning of the ridge whole tile



Natural | Bordeaux | Brown | Black | Copper | Anthracite Grey

## Beginning of the ridge only front



Natural | Bordeaux | Brown | Black | Copper | Anthracite Grey

## Front plate of ridge tile



Natural | Bordeaux | Brown | Black | Copper | Anthracite Grey

## End plate of ridge tile



Natural | Bordeaux | Brown | Black | Copper | Anthracite Grey

# ROOFING EQUIPMENT

## ROLLABLE RIDGE VENT

Universal element of roofing equipment designed for dry execution of ridge which ensures ventilation underneath the ridge tile. On the edge on both sides of the vent, there are self-adhesive tapes for attaching to the tile.

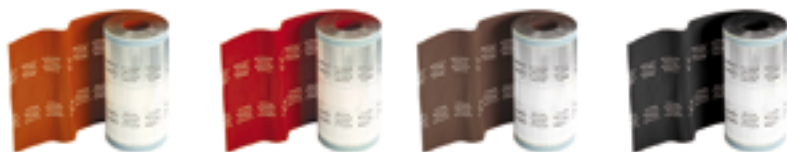

Brick

Bordeaux

Brown

Black



• Tape with: **280 mm**



• Tape length: **5m**



• Free cross-section for ventilation: **145cm<sup>2</sup>/m per roof plane**



• Consumption: **~1m VR 280 ALU/m' ridge**



• Available colors: **brick, burgundy black, brown**

## RIDGE BATTEN GRIP

A metal element used to fasten the ridge batten. By using it and placing it correctly, you get an accurate and straight line of ridge tiles.



• Length **210 mm**



• "U" profile size **20x50x55mm**



• Consumption: **~1m iece / 0.8m ridge**

## BIRD PROTECTION GRILLE

Bird protection grille is used at the lower roof ventilation openings so as to prevent birds and insects from entering the roof structure.



Brick

Black

Brown



• Strip width: **100 mm**



• Strip length: **5m**



• Free cross-section for ventilation: **80%**



• Consumption: **~1m perforated strip / m' drip**



• Available colors: **brick, black, brown**

## CLASP AGAINST STORMS

Zinc storm resistant fastener is used in areas with frequent and strong winds. It increases the safety of the construction and the resistance of tiles to wind gusts. It is placed sideways along the tile slot. The fastener is universal for all models of Nexe tiles.



• Consumption: **it is recommended to be placed on each tile along the roof perimeter (eaves, ridge, left and right roof edge). On the rest of the roof it is placed on every fourth tile.**

## RIDGE TILE CLAMPS

Painted metal fastener used to fasten ridge tiles in the dry installation process. A tile is screwed to the batten the, and then the other screw is used to connect the clamp directly to the batten.



Brick

Bordeaux

Brown

Black



• Consumption: **1 piece / 1 ridge tile**



• Available colors: **brick, burgundy, black, brown**



## END CAP

The end cap is used to close the ridge ends while preserving ventilation. It prevents birds and insects from entering the roof structure.



Brick

Bordeaux

Brown

Black



• Free cross-section for ventilation: **16cm / pc**



• Available colors: **brick, burgundy, black, brown**

## METAL SNOW GUARD R

Their purpose is to prevent the occurrence of avalanche-like snow sliding with Glinex Trend and Klasik + tile models.



Brick

Bordeaux

Brown

Black



• Material: **Galvanized steel sheet**



• Available colors: **brick, burgundy, brown, black**

## METAL SNOW GUARD IDEAL

Their purpose is to prevent the occurrence of avalanche-like snow sliding with Ideal and Ideal + tile models.



Brick



• Material: **Galvanized steel sheet**



• Available colors: **brick**

## ROOF UNDERLAYS

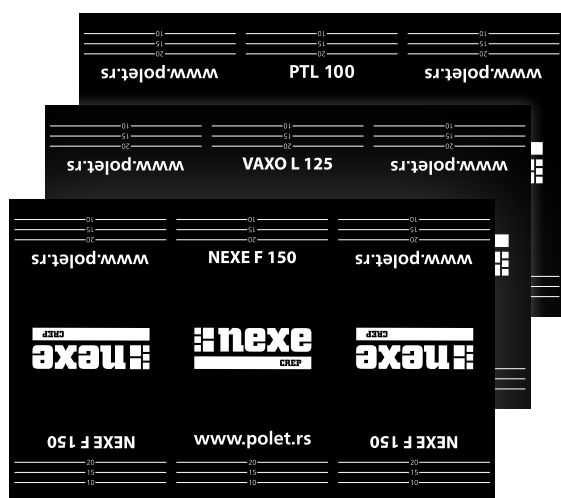

Highly vapor-permeable, watertight underlays **NEXE F 150, VAXO L 125 and PTL 100.**

**Functions of vapor-permeable, watertight underlays NEXE F 150, VAXO L 125 and PTL 100:**

- enable proper drying of the structure and insulation materials
- enable the creation of a pleasant microclimate in the space
- due to their properties, they increase the thermal insulation properties by about 10%
- extend the life of the structure, understructure and cover
- possibility of placing on the roof formwork, purlins or sloping concrete slab
- prevent the penetration of pests and thus protect the structure from decay and rot
- prevent cooling and condensation of water in the thermal insulation

### BASIC CHARACTERISTICS of underlays:

**NEXE F 150**

**VAXO L 125**

**PTL 100**

CHARACTERISTICS	MEASURING UNIT	PTL 100	VAXO L 125	NEXE F 150
Length	m	50	50	50
Width	m	1,5	1,5	1,5
Area	m <sup>2</sup>	75	75	75
Weight	g/m <sup>2</sup>	100 (±15%)	125 (±15%)	150 (±7%)
Tear strength	N/50mm	220/130 (±20%)	240/120 (±30%)	290/235 (±20%)
Water penetration resistance	class	W1	W1	W1
Reaction to fire	class	F	F	F
Low-temperature flexibility	°C	-40	-40	-40
Vapor permeability	Sd	0,02 m (±15%)	0,03 m (±15%)	0,02 m (±15%)
UV resistance	month	2	3	3
Consumption: ~ 1.1 m <sup>2</sup> of underlay / m <sup>2</sup> of roof surface				

# ECO DECLARATION



We take care of every segment of our company's business, and we have focused on investing in new technologies that reduce emissions of pollutants. Since 2020, Nexe group has been certified by environmental product declaration according to **SRPS 14025:2007** and **SRPS EN 15804:2020** for the production of clay tiles and shaped clay pieces issued by the ***Institute for Testing of Materials - Institut IMS. a.d. Republic of Serbia.***

***Type of Declaration - "Cradle to grave"***  
Number of declaration **EPD-IMS-2020-02-SR**









# TECHNICAL SUPPORT

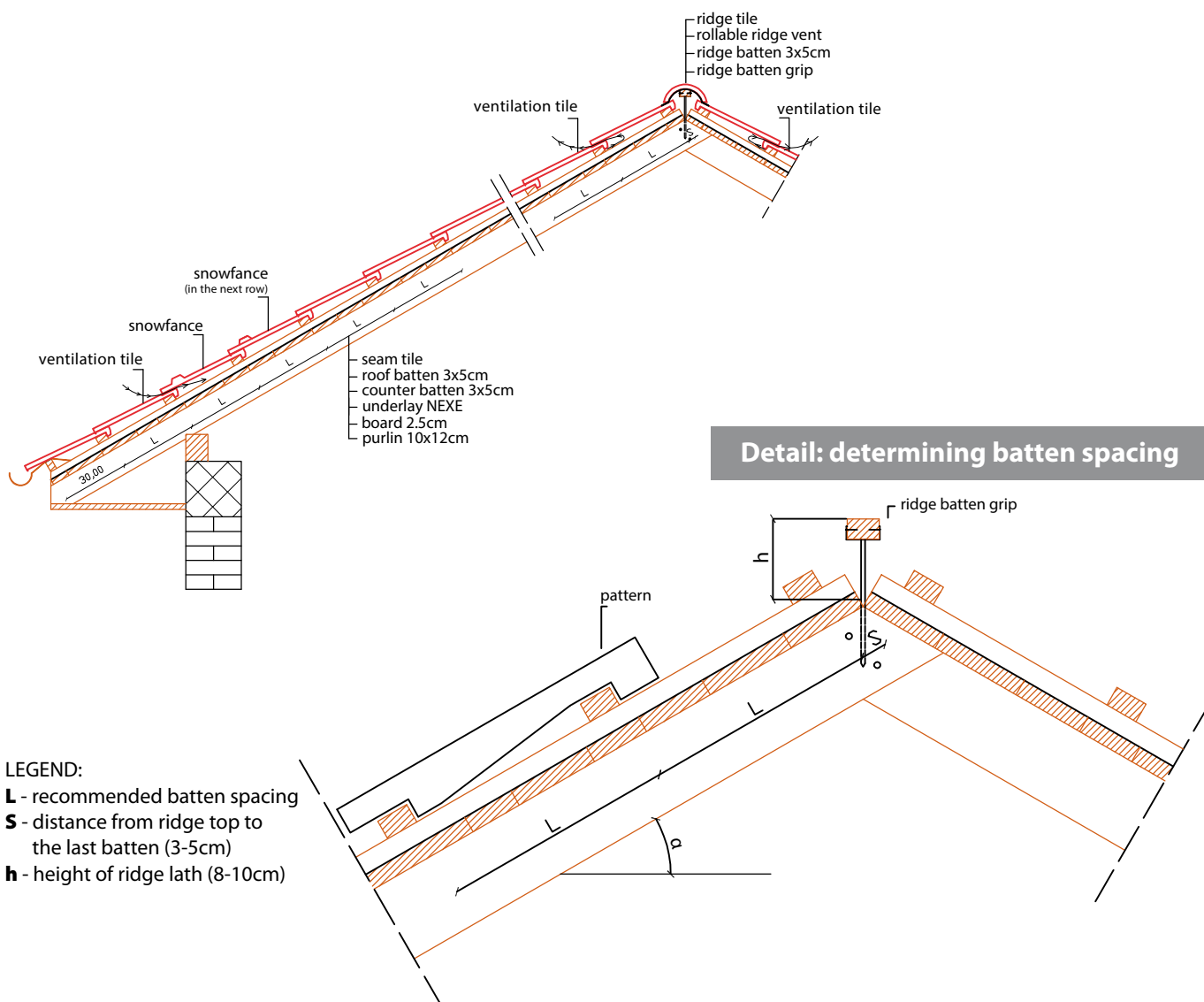

## ROOF CROSS SECTION



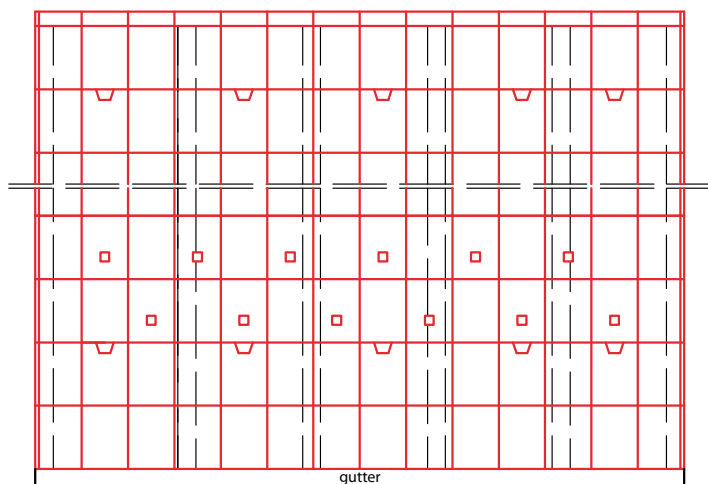

## DRAWING OF SPECIAL ELEMENT INSTALLATION



**LEGEND:**

-  Special tile VENTILATION TILE
-  Special tile SNOWFANCE
-  Ridge tile

-  Special tile END RIGHT
-  Special tile END LEFT





# WARRANTY



for roof tile

purchased on

(name, location, and company stamp)

for installation on the building

(address)

account number

customer

(Name and Surname)

## 40 YEAR WARRANTY

1. AD Polet IGK Novi Becej guarantees that the supplied roof tiles in the above mentioned period (40 years) will fulfill the quality criteria defined by the national standards SRPS EN 1304 I SRPS EN 1024, SRPS EN 538, SRPS EN 539-1, SRPS EN 539-2.

2. If the roof tile within the warranty period does not meet any of the criteria defined by the abovementioned standards substantially affecting its functionality, AD Polet IGK Novi Becej shall be obliged to replace all roof tiles in which deficiencies are found, related to the characteristics of the tiles from the warranty coverage.

3. Deficiencies relating to the following are excluded from the warranty:

- mechanical damages caused by force majeure (eg natural disasters)
- temporary changes in roof tile aesthetics that do not impair its functionality, whether caused by transportation, handling, or are the result of adverse weather conditions in the environment.
- inappropriate use of roof tiles

4. Customer undertakes to carry out the installation of roof tiles in accordance with the Regulations on technical standards for design and execution of finishing construction works, as well as in accordance with the manufacturer's instructions relating to the application of the product, which are contained in the manufacturer's data sheet prevailing at the time of making the roof.

5. Warranty period of 40 years shall apply only if the conditions under Items 2 and 4 are met.

6. The warranty period starts from the month and year of manufacture of roof tiles (month and year of manufacture are indicated by a permanent mark on the back of roof tile).

7. When making a complaint regarding the quality of roof tile, the customer shall:

- send the complaint to the manufacturer in a written form
- specify the type of roof tile, quantity, place of installation, reasons for complaint, date of purchase and type of damage.
- submit a bill for the goods purchased and a warranty card along with the complaint!

8. Warranty shall be valid for the following types of roof tiles: IDEAL, IDEAL+, GLINEX TREND, KLASIK+, BIBER ROOF TILE (natural and engobed).

**nexe**  
ROOF TILE

AD POLET  
Construction ceramics industry  
Železnička 13,  
23272 Novi Becej  
The Republic of Serbia

Phone: +381 (0) 23 771 971  
+381 (0) 23 771 970  
Fax: +381 (0) 23 773 300  
E-mail: polet@nexe.rs





AD POLET IGK  
23272 Novi Bečej, Železnička 13, Republika Srbija



[www.polet.rs](http://www.polet.rs)



Tel: +381 (0)23 771 970, +381 (0)23 771 971  
Fax: +381 (0)23 773 300



[polet@nexe.rs](mailto:polet@nexe.rs)



 **nexe**  
ROOF TILE